

ANSYS NVH Solutions for Electric Vehicles

→ Simulating the noise, vibration and harshness (NVH) of an electric motor is important for proper electromagnetic (EM) and vibro-acoustic design of electric vehicles (EVs). This paper describes ANSYS' solutions to characterize the NVH effects of an electric motor early and accurately in the design cycle to improve vehicle performance and safety. These solutions lower development costs and help support electric mobility (e-mobility) – an application resulting from electrifying transportation. ANSYS solutions enable carmakers to reduce the NVH of electric vehicles, improve customer satisfaction and gain competitive advantage in the automotive sector.

Motivation for NVH Analysis

Electrification of transportation is shaping the future of powertrain and modern propulsion technologies. Since electrification brings significant economic and environmental benefits, EVs are gaining widespread adoption across the world. This trend is supported by the increase in the number of EVs on the road in the United States, which has quadrupled in the last five years.

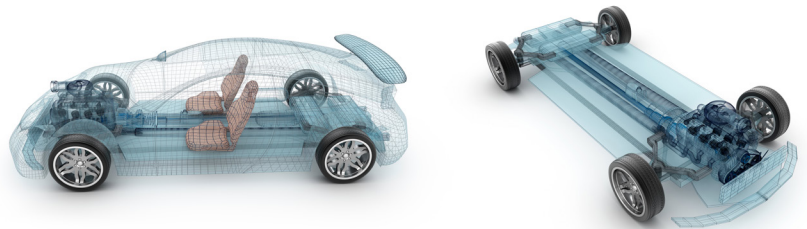

Figure 1. Representative image of a vehicle's powertrain

In addition to reducing carbon emissions and operational costs, EVs are quieter than internal combustion engines. But tonal noise originating from the electric motor is a big concern for engineers designing these vehicles. NVH is often felt by any occupant of a moving electric vehicle. At varying motor speeds, NVH is unpleasant and may cause fatigue on the vehicle and discomfort for its occupants.

An electric motor is a key segment of the powertrain. Optimal design of the electric motor is important for reducing the overall NVH and ensuring proper operation of a vehicle's powertrain. Simulating electric motors using ANSYS Maxwell saves time, reduces the number of hardware prototypes and fosters innovation. ANSYS Mechanical simulations can predict the vibration and noise excited by electromagnetic forces within the electric machine, which contribute a significant fraction of the overall powertrain noise. Simulation results from Maxwell and Mechanical provide key input to realize the goal of measuring auditory perception and assessing a vehicle's NVH performance. These results are utilized in ANSYS VRXPERIENCE Sound to synthesize and evaluate motor noise and its impact on human perception. Essentially, the multiphysics analysis – combining Maxwell, Mechanical and VRXPERIENCE Sound – results in an audio file of the motor's acoustic configuration to explicitly produce and hear its sound at varying speeds.

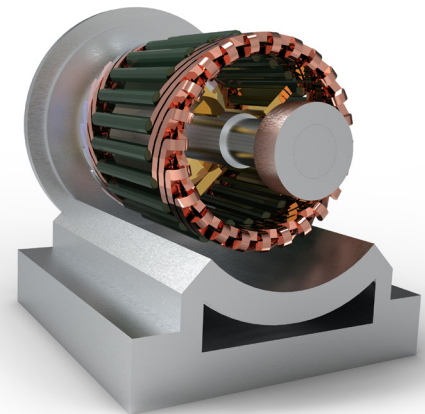

Figure 2. 3D electric motor design mounted on a base – all generated using ANSYS Maxwell

ANSYS NVH Solutions

ANSYS multiphysics analysis for NVH has four segments. First, the electromagnetic simulation of the motor determines the radial, tangential and axial forces associated with the machine's performance. Second, the structural simulation incorporates these forces in the presence of the motor housing. The third segment involves acoustic representations of the radiating vibrational noise. Finally the acoustic results are converted to an audio file. This multiphysics approach gives an overall picture of the electromagnetic, structural and acoustic performance of the motor. With the complete acoustic profile of the motor, electrical and mechanical engineers can make changes to the design to reduce NVH while satisfying electrical performance requirements.

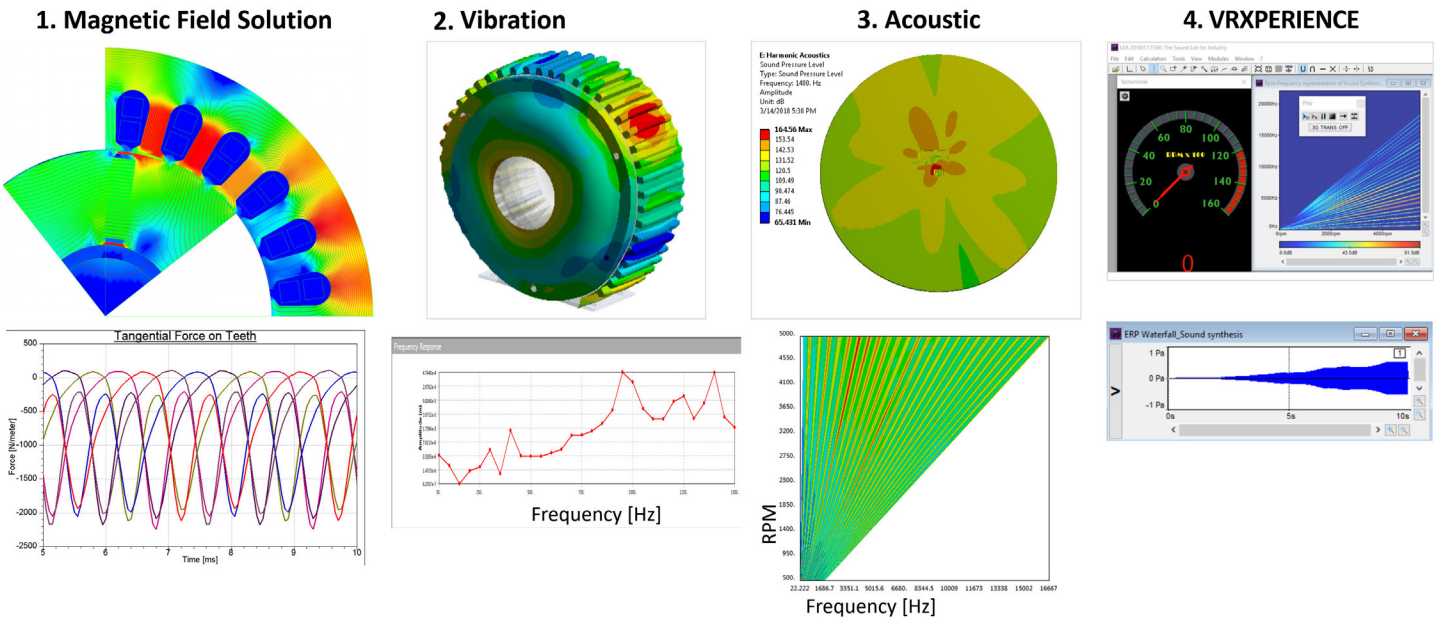

Figure 3. ANSYS NVH solution flow

The multiphysics solution includes electromagnetic forces generated by the electric motor topology, the additional mechanical effects amplified by the structural vibrations and resonances, as well as the radiating vibrational noises. Combining electromagnetics, structural and acoustic engineering enables engineers to holistically optimize an EV's NVH.

The most important NVH phenomenon for an electric motor is the whining noise caused by electromagnetic (EM) forces, which can be calculated in ANSYS Maxwell for both single and multiple motor speeds. The EM results can be transferred to ANSYS Mechanical to simulate the system's structural dynamic response for both modal and harmonic analyses. This paves the way for modeling the airborne sound propagation and acoustic response of the equivalent radiated power (ERP) to account for the structural contribution in the sound generated by the powertrain. The output of the acoustic simulation is the spectral response of the noise, which can be used in ANSYS VRXPERIENCE Sound to develop waterfall plots to comprehend the motor's acoustic profile by analyzing and hearing the sound.

The motor's sound is dependent on the results of the electromagnetic and mechanical analyses. This sequential, multi-step NVH analysis provides accurate, electromagnetically excited acoustic noise to evaluate the overall quality of the motor from the acoustic standpoint. Moreover, engineers can perform comprehensive psychoacoustic analyses by including parasitic aerodynamic and mechanical noise sources. This multiphysics solution is valuable throughout the full process of developing electric-powered drivetrains.

ANSYS Maxwell – the Key for Optimizing NVH

ANSYS Maxwell enables engineers to create and test a broad range of electric motor digital prototypes. In general, electric motor geometries are complicated. But designing electric motors using ANSYS Maxwell is easy. The entire motor design is automated thanks to template-based design capabilities in Maxwell. So, the engineer only has to specify the values for typical motor parameters — number of phases and poles, slots, materials, motor dimensions, coil pitch, etc. Once the parameters are specified, Maxwell automatically generates the motor. Simulation of the motor in Maxwell over wide-ranging operating conditions involving varying speeds, current, power, torque, etc., gives valuable insights into the motor's electromagnetic performance as well as the magnetic forces that are generated during operation of the machine. Calculating the magnetic forces in the motor is a critical input for mechanical and acoustic analyses and is the first step towards predicting NVH.

Both object- and element-based magnetic forces can be configured in Maxwell. These capabilities allow accurate calculation of forces under both balanced and unbalanced operating conditions of the machine. Thus, regular forces on discrete stator teeth, and forces due to high switching frequency or fault conditions can be modeled accurately. The fault conditions, like the motor's unbalanced magnetic pull forces due to different types of eccentricities, are accurately characterized. Radial, tangential and axial forces as well as the moments are calculated at multiple speeds of the motor in the time domain and converted to frequency domain using Fourier transformation.

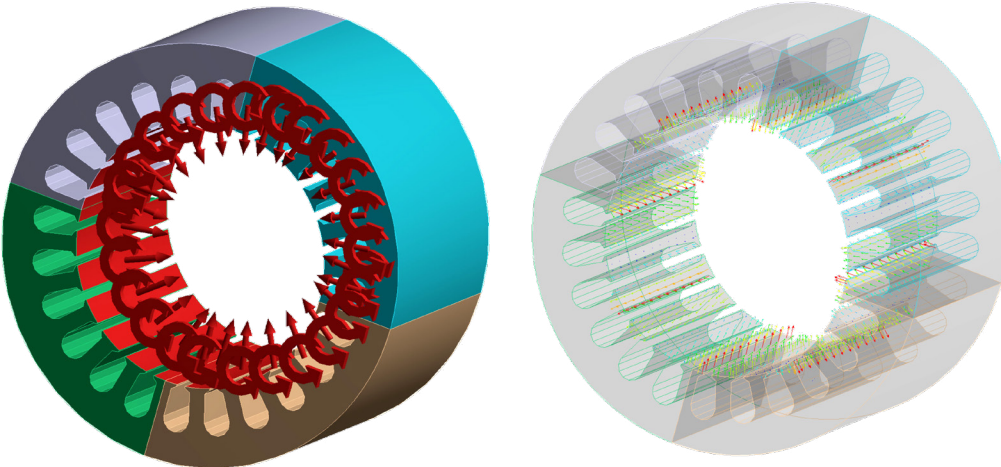

Figure 4. Object-based (left) and element-based (right) magnetic forces can be used for either balanced or unbalanced operating conditions

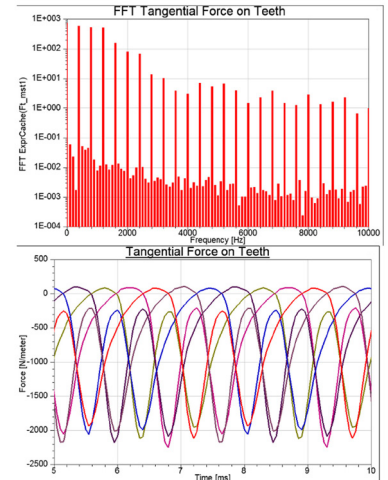

Figure 5. Tangential forces on teeth in ANSYS Maxwell

It is worth noting here that for simulation efficiency in minimizing time and computational resources, the smallest possible simulation model is automatically generated in Maxwell. Its symmetrical topology is exploited in the analysis to obtain the complete electromagnetic forces and the magnetic field solution at varying speeds. This is followed by generating the motor housing automatically based on the template inputs. Engineers can also import a motor and housing model directly to ANSYS Maxwell.

Advanced post-processing capabilities enable generation of magnetic field streamlines inside the motor, as well as depiction of the fields as vectors or a “cloud” representation of field intensity. Interactive post-processing of the magnetic field data gives a complete picture of the electromagnetic characteristics and forces inside the motor.

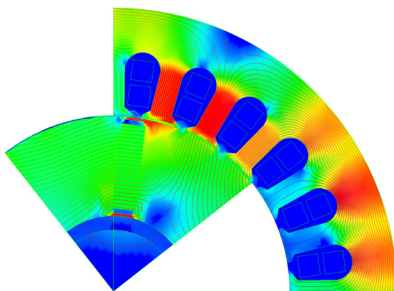

Figure 6. 2D Magnetic fields at 3,000 rpm

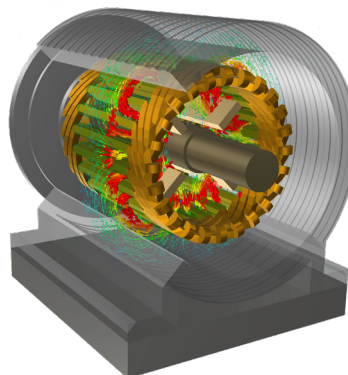

Figure 7. Magnetic field shown as vectors and a cloud of magnetic field intensity

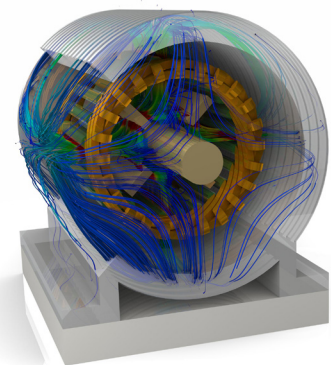

Figure 8. Magnetic field streamlines inside the motor

Structural Response of the Motor and Housing in ANSYS Mechanical

The electromagnetic forces are transferred to Mechanical via ANSYS Workbench, a platform for conducting multiphysics simulations. The forces are applied as inputs in Mechanical to analyze the system’s structural dynamics response. Object-based force mapping (see Figure 4) techniques can be used to model the presence of discrete gaps for each tooth. This approach is useful when modeling 2D magnetic to 3D structural coupling characteristics.

Object-based force mapping eliminates the need for force-density distribution mapping, resulting in significant reduction in simulation time. For various types of electric machines, such as those with skewed stators and rotors, electric motors with eccentric rotors, transverse flux machines, or axial flux motors, the 3D effects may not be captured accurately in object-based mapping methods. For these types of motors, unique element-based force mapping methods can be used in Mechanical to accurately characterize the 3D effects of these forces. Alternative force-mapping methods give users the flexibility for harmonic force calculation and force transfer techniques depending upon the 3D effects of the electric motor design. Analyses of the motor in Mechanical include modal, free-vibration simulations to determine resonant frequencies, coupling and mode shapes. Magnetic forces can also be used in a harmonic vibration analysis to calculate the absolute magnitudes of the vibrations.

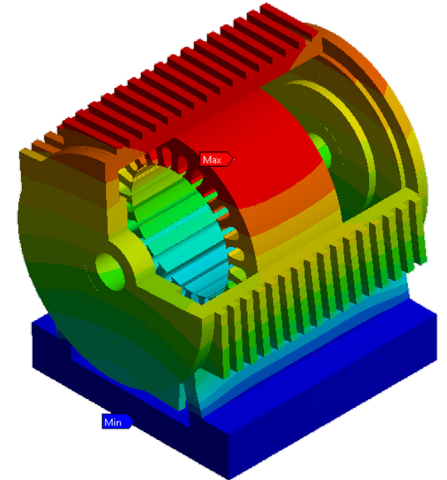

Figure 9. Deformation of the motor in ANSYS Mechanical

Acoustic Response in Mechanical

The structural vibrations are used in calculating the equivalent radiated power (ERP) and sound pressure levels during acoustic, fatigue and optimization analyses. ERP calculations estimate the structure-borne noises. The acoustic response depicts airborne sound propagation as sound pressure levels (SPLs). Surface vibrations typically cause changes in sound pressure levels in air. ERP gives a structural approximation for radiated noise based on the surface velocity. The complete acoustic simulation gives accurate results representing sound pressure levels, as well as far-field results depicting directionality and individual microphone responses. Mechanical generates acoustic data representing ERP at different frequencies and revolutions per minute (rpm).

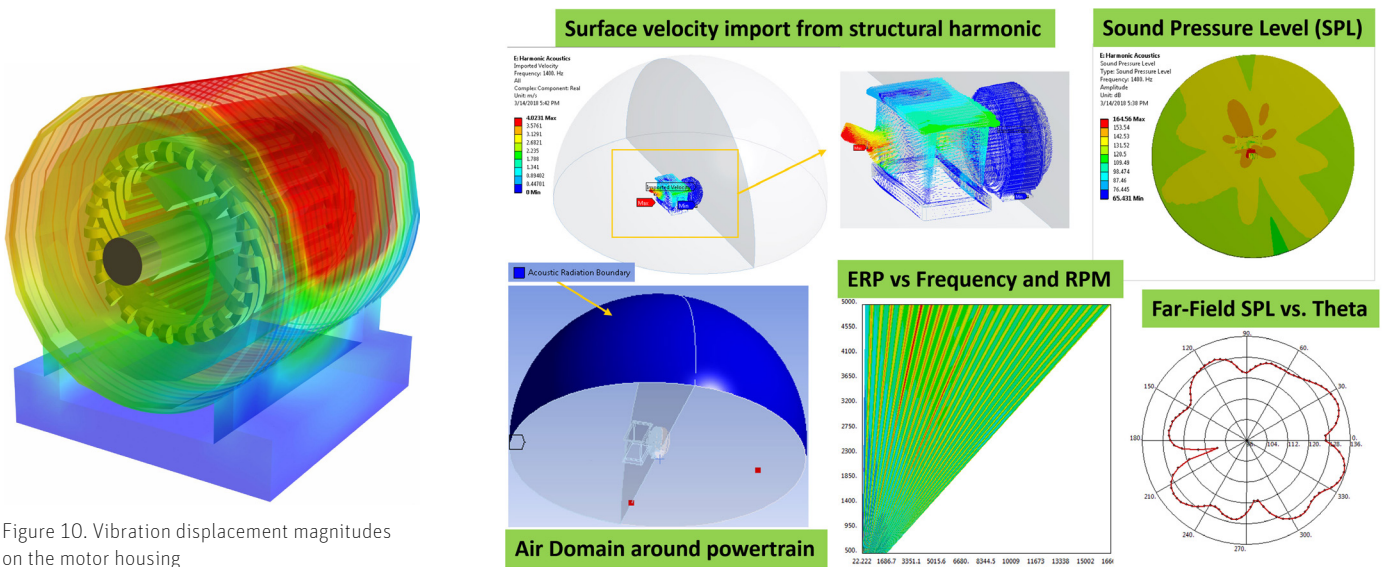

Figure 10. Vibration displacement magnitudes on the motor housing

Figure 11. Acoustics and ERP

Acoustic Experience – Hearing the Motor in ANSYS VRXPERIENCE

The acoustic data from Mechanical is used to produce the motor noise in VRXPERIENCE Sound, a premier tool for sound design, synthesis and measuring auditory perception. The acoustic data is imported into VRXPERIENCE to convert the computed ERP into an audible format of a wave file, enabling users to hear the sound of the electric motor at varying rpms. Hearing the motor enables engineers to isolate and identify sub-components of the acoustic profile and investigate the influence on human perception. The spectral data represent frequency points and decibel values at different discretized rpm values. The audio synthesis considers a linear rpm ramp-up, using linear interpolation between specified rpm values, to create a smooth transition between the specified spectral data. The corresponding time-domain plot for this spectral data is generated as illustrated in Figure 12. From here a spectrogram is generated at a click of button resulting in a waterfall diagram shown in Figure 13.

At this point, engineers can simply play the synthesized audio in VRXPERIENCE Sound to hear the motor noise. Different metrics of perceived qualities such as loudness, sharpness, roughness and fluctuation strength quantitatively describe the auditory perception. All these metrics can be analyzed in VRXPERIENCE Sound. The solution can be attributed to psychoacoustics, a defining feature in VRXPERIENCE Sound that allows users to effectively dissect the listening experience. Understanding the perception of sound and its physiological and emotional impact helps in determining sound quality and reducing an EV's NVH. The audio synthesis of the motor's acoustic response in VRXPERIENCE Sound enables users to weigh in on the acceptable thresholds and create quality indicators based on psychoacoustic metrics. The motor's audio as well as its pictorial representation through waterfall plots allow users to zero in on areas on the plot and identify and isolate the frequencies where sound quality could be improved. Alternatively, the incriminated spectral component can be removed on the waterfall plots, which enables users to listen to improved versions of the audio and define sound targets with the desired optimized quality. This feedback is important for the electrical engineers to make design changes and reduce the vehicle's NVH.

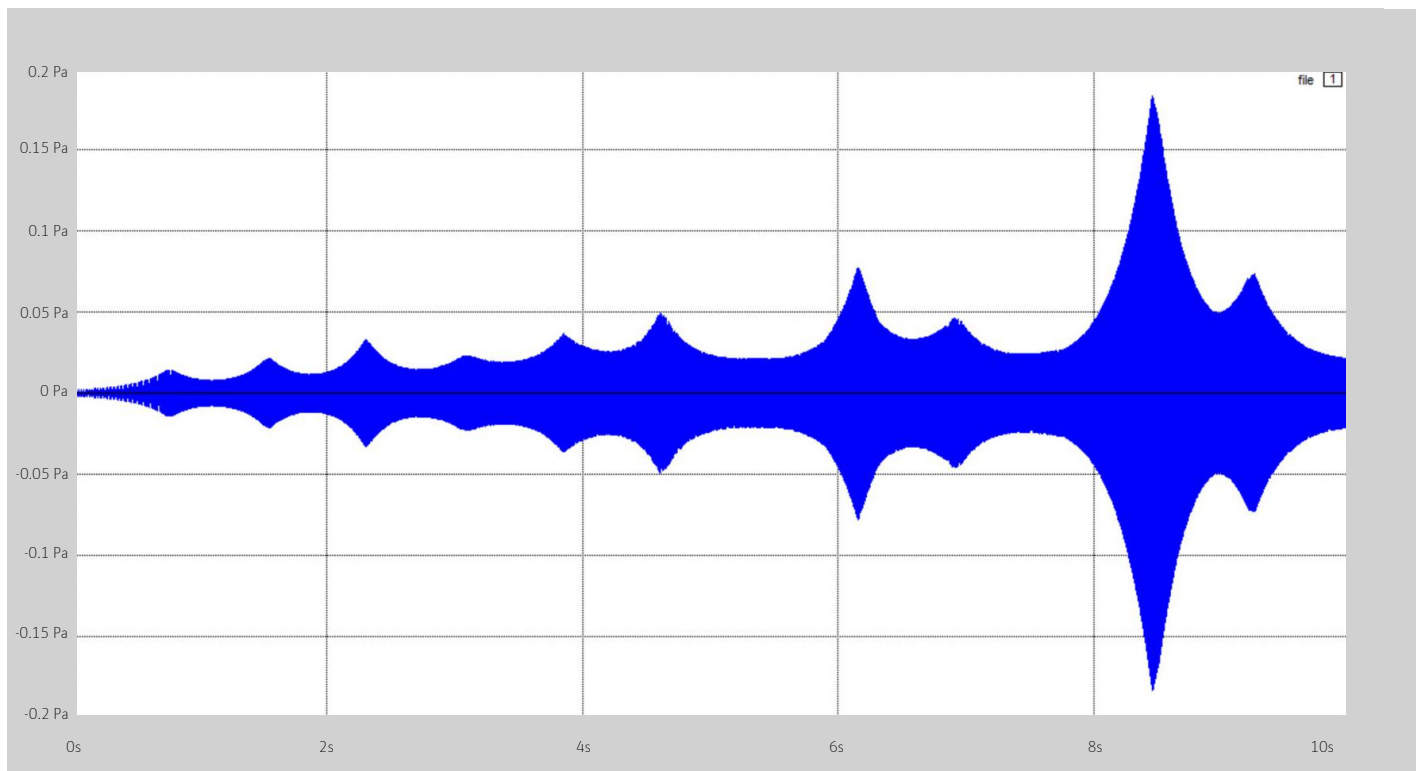

Figure 12. Spectral data displayed in time domain plot

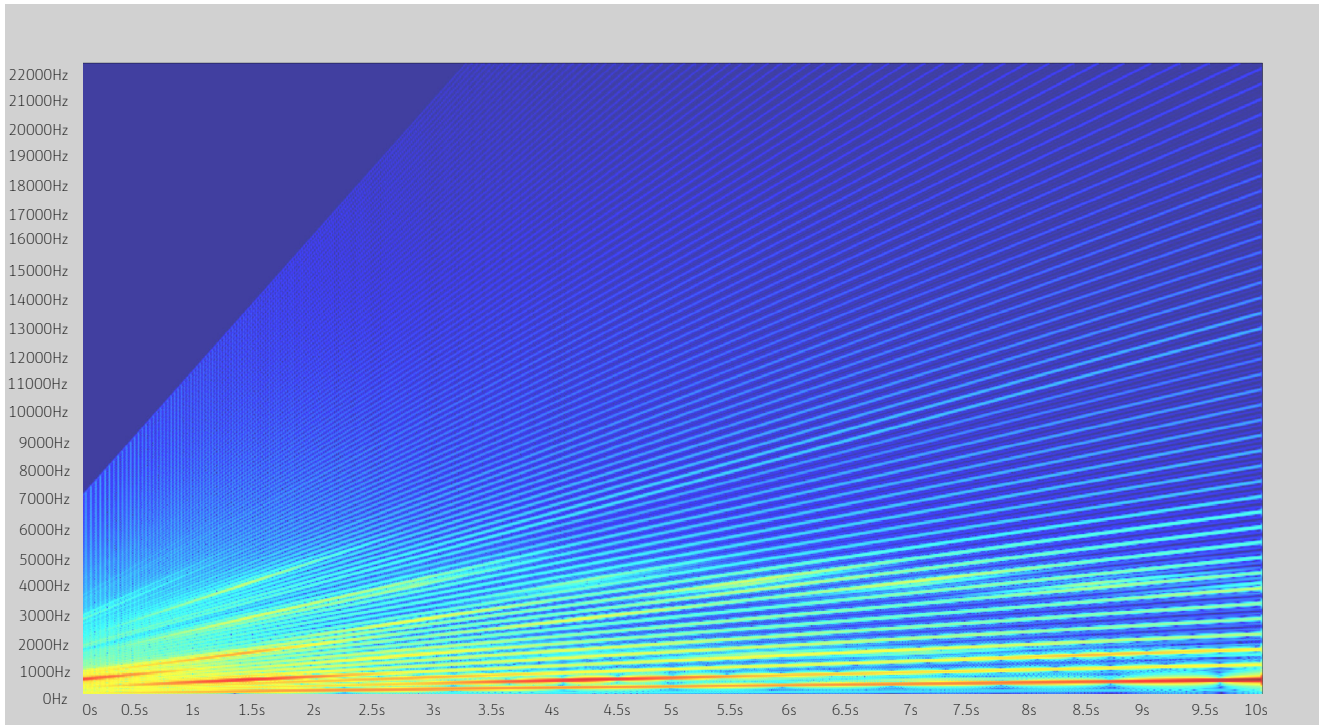

Figure 13. Waterfall diagram for an interior permanent magnet (IPM) motor

Design Changes for NVH Reduction

A variety of system design changes can be made to related parts of the motor to optimize the impact of acoustics. The vibro-acoustic performance of electric machines is related to the electromagnetic forces as well as its mechanical behavior. The electromagnetic forces depend on air gap flux density, number of poles, number of slots in the stator, winding type and fault conditions — all of which can be analyzed in Maxwell. A large parametric sweep of design types can facilitate selection of the motor with highest torque but smallest force ripples causing NVH.

Once the basic motor type and topology are selected, system optimization can occur by adjusting parameters across the circuit, magnetic and structural models. The optimal changes may depend on the type of motor, whether it is a permanent magnet motor with internal or surface magnets or switched reluctance or induction machines. The key parameters for reducing radiated acoustic noise may depend on the structural housing, arrangement of fins used for cooling, minimization of eccentricity or filtration of switching currents. Any parameter used to define the circuit, magnetic or structural model can be fine-tuned through a built-in design exploration and optimization process, thereby improving the motor performance and minimizing NVH.

We investigate the acoustic response directly in ANSYS VRXPERIENCE, which provides critical feedback for engineers to hear and experience the noise. Moreover, this tool quantifies values of perception in the noise, and allows the user to hear the noise as different frequencies are adjusted. This can identify how design changes from the design exploration study affect noise perception. We can then confidently select the optimal model design in terms of overall decibels and perceived quality across motor operation.

As an example, consider a permanent magnet (PM) motor design's NVH performance with and without stator wedges. The acoustic profiles for both original (without wedges) and modified (with wedges) designs were synthesized using VRXPERIENCE Sound. The resulting waterfall plots are displayed, respectively, on top and bottom of Figure 14. A further psychoacoustic analysis is plotted in Figure 15, where loudness can be compared between the two designs. Figure 14 shows that, in the original design (top), a resonance around 500 Hz creates a strong amplification of the most prominent tonal components. This translates into large loudness increases in Figure 15 at instants where prominent tones reach around 500 Hz (roughly 2, 4 and 10 seconds).

Conversely, on the modified design, the resonance area is shifted to an area around 1500–2000 Hz, which the most prominent tones do not reach. The loudness in Figure 15 then remains much more stable, which proves that the sound perception has been improved in the modified design.

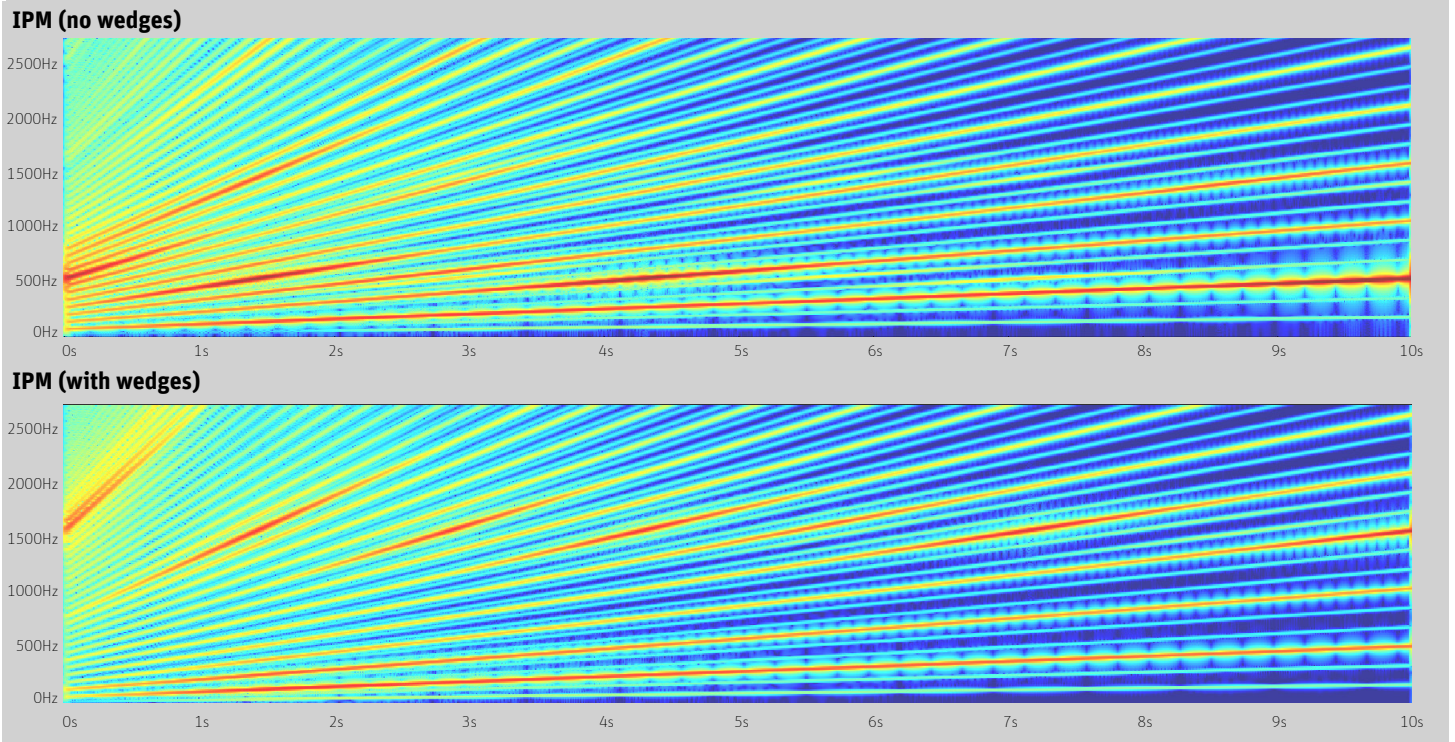

Figure 14. Waterfall diagrams of the original (top) and modified (bottom) designs

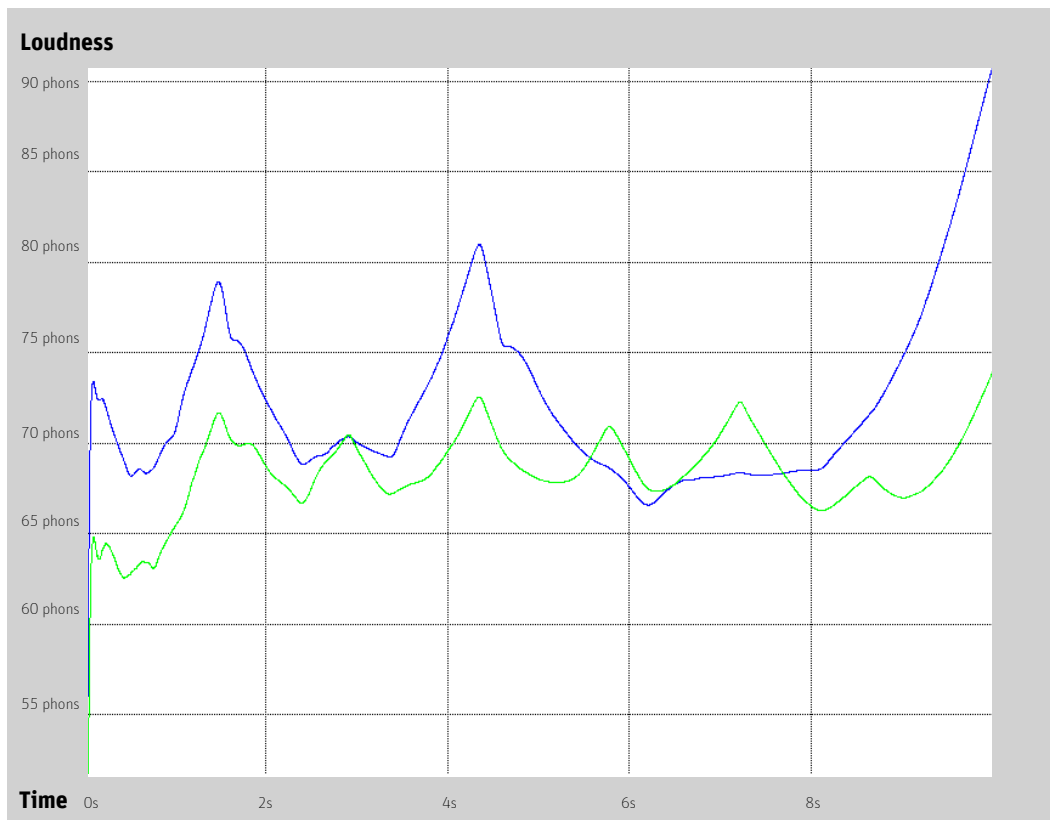

Figure 15. Loudness over time for the original (blue) and modified (green) designs

Conclusion

This paper described the benefits of using ANSYS multiphysics solutions for reducing the NVH of electric motors at multiple RPMs. The ANSYS suite of tools provides end-to-end solutions for understanding sound sources, paths and perception. The unified multiphysics solution enables engineers to work with parameters associated with stator, rotor and housing, while also giving them the capability to evaluate the electrical, mechanical and acoustic performance of the electric vehicle simultaneously. These highly accurate and complete solutions from ANSYS help engineers succeed in diagnosing and optimizing acoustic signatures in electric machines.

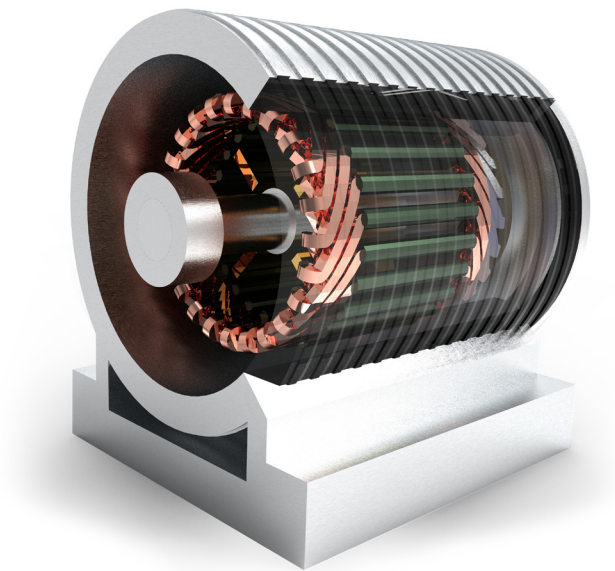

Figure 16. A cut-away view of an electric motor in ANSYS Maxwell

ANSYS, Inc.
Southpointe
2600 ANSYS Drive
Canonsburg, PA 15317
U.S.A.
724.746.3304
ansysinfo@ansys.com

If you've ever seen a rocket launch, flown on an airplane, driven a car, used a computer, touched a mobile device, crossed a bridge or put on wearable technology, chances are you've used a product where ANSYS software played a critical role in its creation. ANSYS is the global leader in engineering simulation. We help the world's most innovative companies deliver radically better products to their customers. By offering the best and broadest portfolio of engineering simulation software, we help them solve the most complex design challenges and engineer products limited only by imagination. Visit www.ansys.com for more information.

© 2019 ANSYS, Inc. All Rights Reserved.

Any and all ANSYS, Inc. brand, product, service and feature names, logos and slogans are registered trademarks or trademarks of ANSYS, Inc. or its subsidiaries in the United States or other countries. All other brand, product, service and feature names or trademarks are the property of their respective owners.